

1. MO-2303-OD4-300

Ref. No.	Note (注記)	Part No. (品番)	Description	E. C. 変更年月	品名	Amt. Req. 数量
1		SS-7110710-SL	SCREW 11/64-40 L=7.0		マルヒラネシ* 11/64-40 L=7	1
2		118-88609	UPPER SPREADER		ウツカキ*ル-ハ*	1
3		SS-6090630-SP	SCREW 9/64-40 L=6		ヒラネシ* 9/64-40 L=6	1
2. MO-2304-0A4-150						
4		118-76059	PRESSER FOOT ASM.		オサエ クミ	1
5		117-92900	STITCH TONGUE		イトス*リタ*イ	(1)
6	001	118-76067	PRESSER FOOT ASM.		オサエクミ (2ヒ*カ*ート*ツキ)	1
7		R4200-H0A-C00	THROAT PLATE		ハリイタ	1
8		118-87007	AUXILIARY FEED DOG		アシ*ヨオクリハ*	1
9		MDC-100B0800	NEEDLE DCX1 #8		ハリ DCX1 #8	1
3. MO-2304-0D4-200, MO-2304-0E4-300						
10	002	118-81455	PRESSER FOOT ASM.		オサエ クミ	1
11	002	118-74609	STITCH TONGUE		イトス*リタ*イ	(1)
12	003	118-81471	PRESSER FOOT ASM.		オサエ クミ	1
13	004	R4200-H0E-D00	THROAT PLATE		ハリイタ	1
14	004	118-88906	CHIP GUARD COVER		スノクス*カハ*ー	1
15	002	MDC-270B0900	NEEDLE DCX27 #9		ハリ DCX27 #9	1
4. MO-2304-0F4-300						
16		118-76257	PRESSER FOOT ASM.		オサエ クミ	1
17		B1509-804-C0A	STITCH TONGUE		イトス*リタ*イ	(1)
18	001	118-76265	PRESSER FOOT ASM.		オサエクミ (2ヒ*カ*ート*ツキ)	1
19		R4200-H0F-D00	THROAT PLATE		ハリイタ	1
20		118-88906	CHIP GUARD COVER		スノクス*カハ*ー	1
21		118-31559	LOOPER HOLDER ASM, B		ウツル-ハ*ウチ* クミ	1
22		SS-9151210-TP	SCREW 15/64-28 L=11.8		ロツカクホルト 15/64-28	(1)
23		118-93609	GAUGE		ウツル-ハ* カイ*ト*ササエ ケ*ーシ*	1

Note (注記) 001 Standard part
 002 For OD4-200
 003 Standard part (OD4-200)
 004 For OE4-300

*All parts other than the above are same as those used in model MO-2304-0D4-300.

国内は特別注文部品
 OD4-200用
 OD4-200特別注文部品
 OE4-300用

上記以外の部品は、MO-2304-0D4-300と同じです。

5. MO-2304-0D6-300

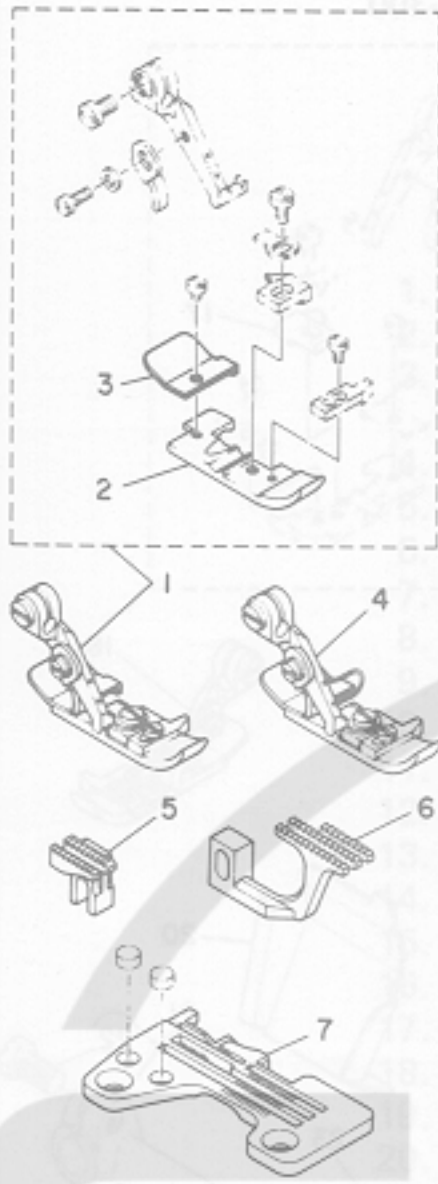

6. MO-2304-0F6-500

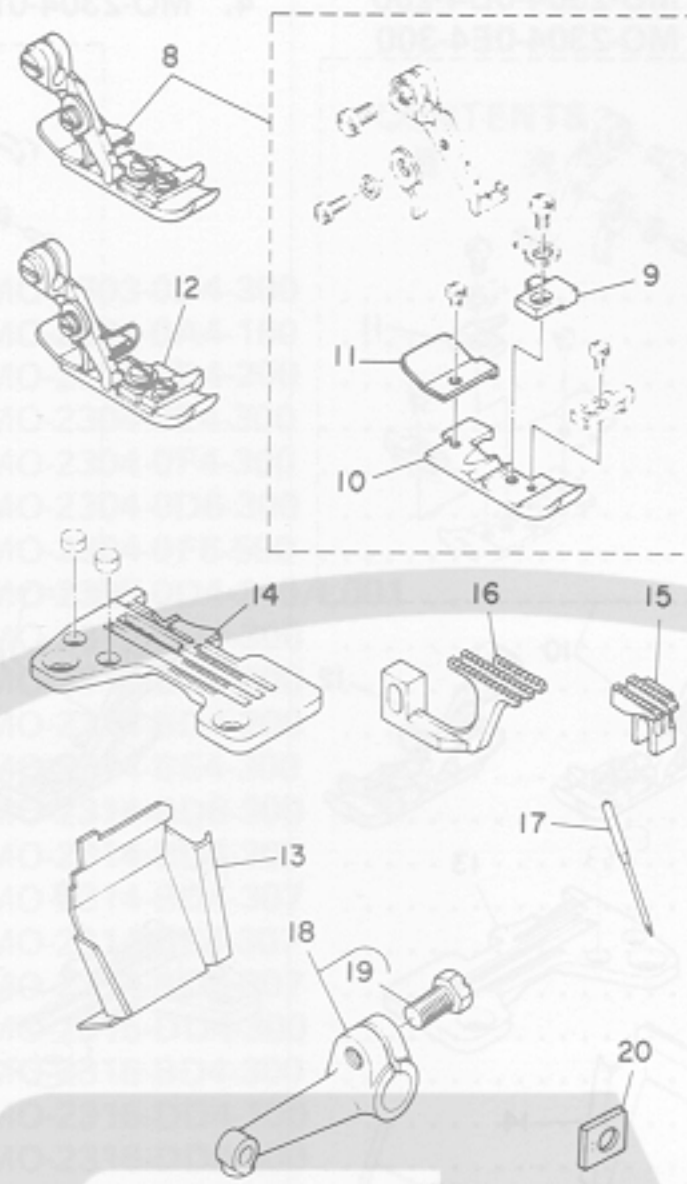

7. MO-2305-0D4-210

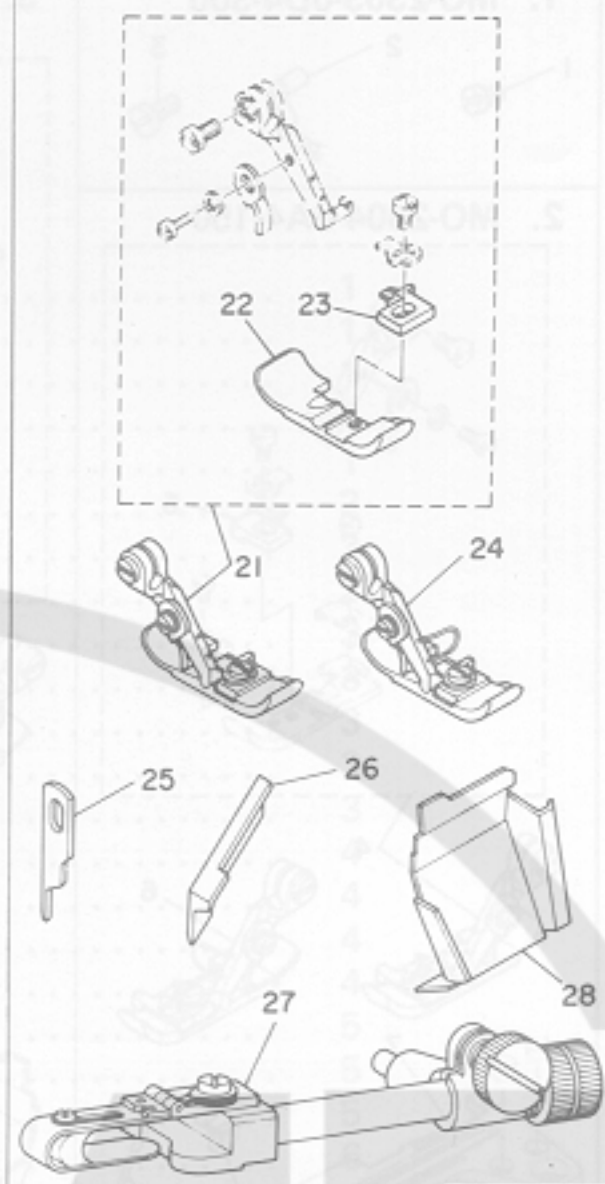

5. MO-2304-0D6-300

Ref. No.	Note 注記	Part No. 品番	Description	E.C. 変更年月	品名	Amt. Req. 数量
1		118-76356	PRESSER FOOT ASM.		プレス フミ	1
2		118-73007	PRESSER FOOT		プレス	(1)
3		B1511-814-000	REAR PRESSER FOOT		カラカントノ	(1)
4	#01	118-76364	PRESSER FOOT ASM.		プレス フミ (2ヒキカ-トツキ)	1
5		118-82206	MAIN FEED DOG		シエクリハ	1
6		118-85100	DIFFERENTIAL FEED DOG		フククリハ	1
7		R4300-H06-E00	THROAT PLATE		ハリイダ	1

6. MO-2304-0F6-500

8		118-76455	PRESSER FOOT ASM.		プレス フミ	1
9		B1509-804-C0A	STITCH TONGUE		イトスハリツクイ	(1)
10		118-73007	PRESSER FOOT		プレス	(1)
11		B1511-814-000	REAR PRESSER FOOT		カラカントノ	(1)
12	#01	118-76463	PRESSER FOOT ASM.		プレス フミ (2ヒキカ-トツキ)	1
13		118-88906	CHIP GUARD COVER		スノクス カハ-	1
14		R4300-H0F-E00	THROAT PLATE		ハリイダ	1
15	*	118-82206	MAIN FEED DOG	0.05/85	118-83303	-
	*	118-83303	MAIN FEED DOG	4.05/85	シエクリハ	1
16	*	118-85100	DIFFERENTIAL FEED DOG	0.05/85	118-85605	-
	*	118-85605	DIFFERENTIAL FEED DOG	4.05/85	フククリハ	1
17		M0C-27081400	NEEDLE DCX27 #14		ハリ DCX27 #14	1
18		118-31559	LOOPERS HOLDER ASM. 9		ツル-ハ クミ	1
19		SS-9151210-TP	SCREW 15/64-28 L=11.8		コブカクネット 15/64-28	(1)
20		118-93609	GAUGE		ツル-ハ カイトツクイ ツク-	1

7. MO-2305-0D4-210

21		118-78550	PRESSER FOOT ASM.		プレス フミ	1
22		B1507-805-000-A	PRESSER FOOT		プレス	(1)
23		118-74807	STITCH TONGUE		イトスハリツクイ	(1)
24	#01	118-78568	PRESSER FOOT ASM.		プレス フミ (2ヒキカ-トツキ)	1
25	#02	118-47506	KNIFE		ヒラメス	1
26	#03	118-45906	UPPER KNIFE		ウツメス	1
27		MAT-90101LAB	BLIND HEMMING ATTACHMENT ASM. (9)		スツヒキ アタツチメント フミ	1
28		118-89003	CHIP GUARD COVER		スノクス カハ-	1

Note (注記) #01 Standard part
 #02 For domestic use
 #03 For export

*All parts other than the above are same as those used in model MO-2304-0D4-300.

国内は特別注文部品
 国内用
 輸出用

上記以外の部品は、MO-2304-0D4-300
 と同じです。

8. MO-2312-CD4-300



9. MO-2312-DF6-500

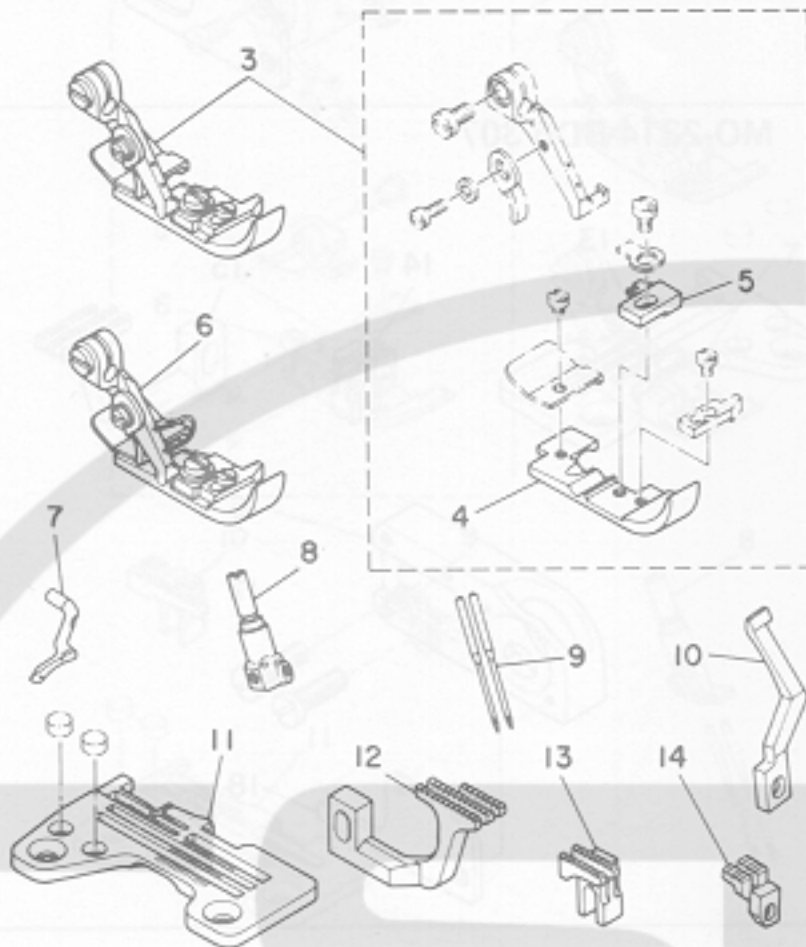

10. MO-2314-BD4-200

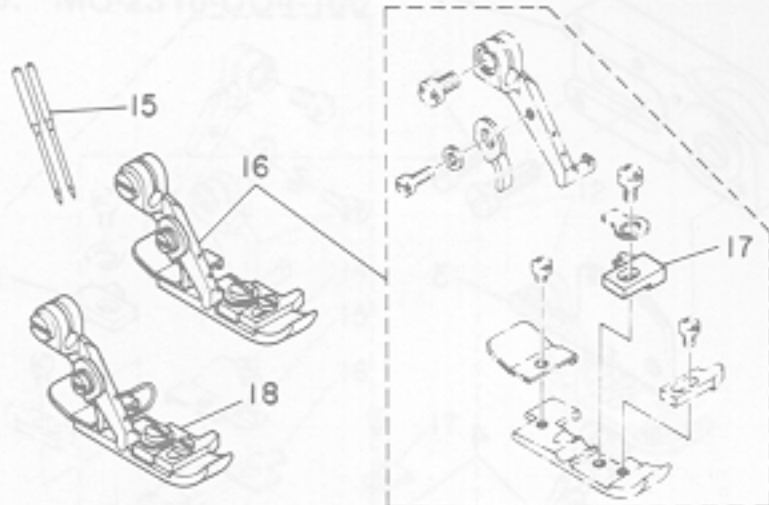

11. MO-2314-BE4-300



12. MO-2314-BD6-300

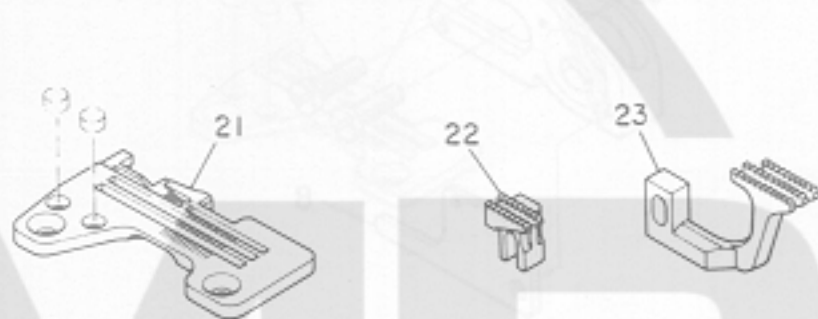

8. MO-2312-CD4-300

Ref. No.	Note 注記	Part No. 品番	Description	E.C. 変更年月	品名	Amt. Req. 数量
1		R4205-MOD-E00	THROAT PLATE		ハヤイフ	1
2		118-69757	NEEDLE CLAMP ASM.		ニードルホルダアサメ クレ	1
9. MO-2312-DF6-500						
3		118-77156	PRESSER FOOT ASM.		プレス足 クレ	1
4		117-90508	PRESSER FOOT		プレス足	(1)
5		117-90607	STITCH TONGUE		イタスリヤグアイ	(1)
6	*01	118-77164	PRESSER FOOT ASM.		プレス足 (2ピッチ-トワウ)	1
7		118-88005	UPPER LOOPER		ウツル-ハ	1
8		118-69955	NEEDLE CLAMP ASM.		ニードルホルダアサメ クレ	1
9		MDC-270B1400	NEEDLE DCX27 #14		ハヤ DCX27 #14	2
10		118-90407	NEEDLE GUARD		ハヤウツ	1
11		R4308-MDF-E00	THROAT PLATE		ハヤイフ	1
12	*	117-90706	DIFFERENTIAL FEED DOG	0.05/85	119-80604	-
	*	119-80604	DIFFERENTIAL FEED DOG	A.05/85	ワウツクハ	1
13	*	118-82503	MAIN FEED DOG	0.05/85	119-80505	-
	*	119-80505	MAIN FEED DOG	A.05/85	シバツクハ	1
14		118-87205	AUXILIARY FEED DOG		アサツクハ	1
10. MO-2314-BD4-200						
15		MDC-270B0900	NEEDLE DCX27 #9		ハヤ DCX27 #9	2
16		118-81554	PRESSER FOOT ASM.		プレス足 クレ	1
17		118-74708	STITCH TONGUE		イタスリヤグアイ	(1)
18	*01	118-81570	PRESSER FOOT ASM.		プレス足 クレ	1
11. MO-2314-BE4-300						
19		R4205-MDE-E00	THROAT PLATE		ハヤイフ	1
20		118-93609	GAUGE		ウツル-ハ カイタツクハ クレ	1
12. MO-2314-BD6-300						
21		R4305-MDD-E00	THROAT PLATE		ハヤイフ	1
22		118-82404	MAIN FEED DOG		シバツクハ	1
23		118-86504	DIFFERENTIAL FEED DOG		ワウツクハ	1

Note (注記) *01 Standard part
 *All parts other than the above are same as those used in model MO-2314-BD4-300.

国内は特別注文部品
 上記以外の部品は、MO-2314-BD4-300
 と同じです。

13. MO-2314-BD4-207

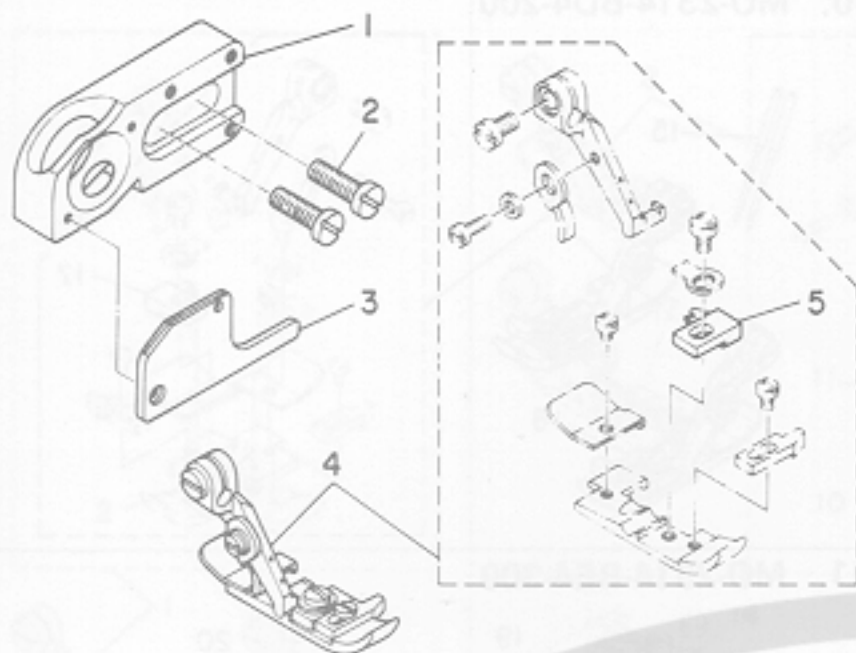

15. MO-2314-BE4-307

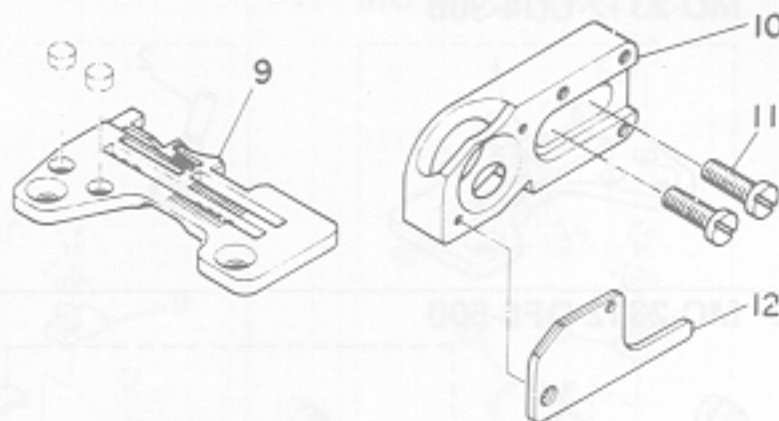

14. MO-2314-BD4-307

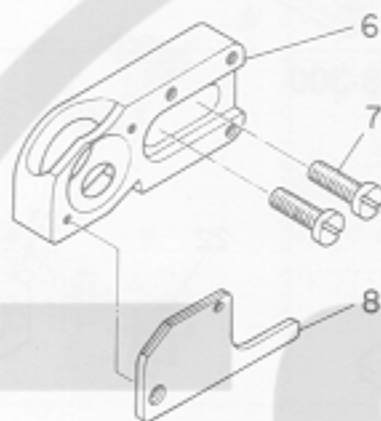

16. MO-2314-BD6-307

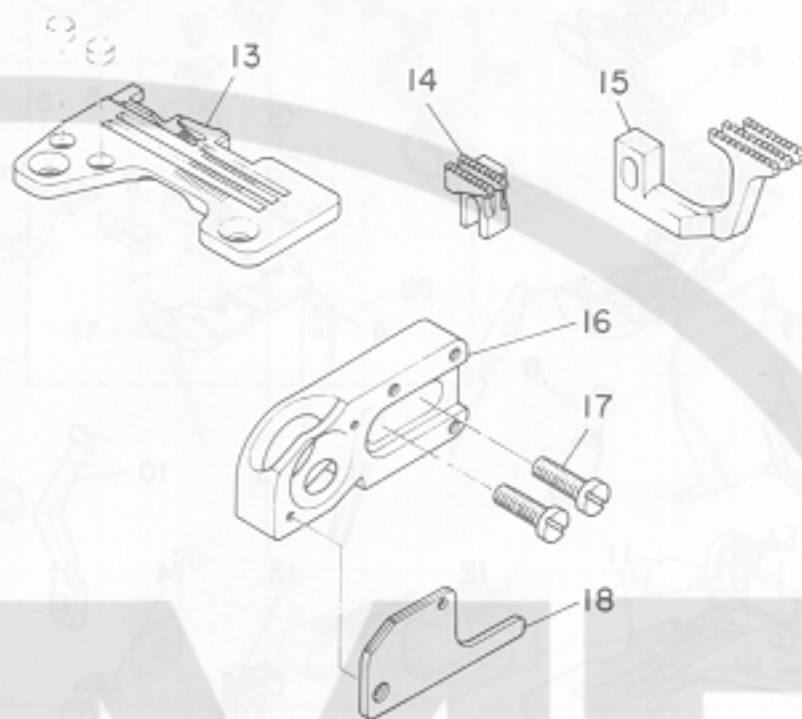

13. MO-2314-BD4-207

Ref. No.	Note 注記	Part No. 品番	Description	E. C. 変更年月	品名	Amt. Req. 数量
1		118-93302	UPPER LOOPER GUIDE SUPPORT		ウツル-ハ° カ°イ°サ°エ B	1
2		SS-7151310-TP	SCREW		ウツル-ハ°カ°イ°サ°エ°シ°	2
3		B2515-704-00B	UPPER LOOPER GUIDE COVER		ウツル-ハ°カ°イ° フタ B	1
4		118-81554	PRESSER FOOT ASM.		オウエ クミ	1
5		118-74708	STITCH TONGUE		イトス°リタ°イ	(1)
14. MO-2314-BD4-307						
6		118-93302	UPPER LOOPER GUIDE SUPPORT		ウツル-ハ° カ°イ°サ°エ B	1
7		SS-7151310-TP	SCREW		ウツル-ハ°カ°イ°サ°エ°シ°	2
8		B2515-704-00B	UPPER LOOPER GUIDE COVER		ウツル-ハ°カ°イ° フタ B	1
15. MO-2314-BE4-307						
9		R4205-H0E-E00	THPOAT PLATE		ハリイタ	1
10		118-93302	UPPER LOOPER GUIDE SUPPORT		ウツル-ハ° カ°イ°サ°エ B	1
11		SS-7151310-TP	SCREW		ウツル-ハ°カ°イ°サ°エ°シ°	2
12		B2515-704-00B	UPPER LOOPER GUIDE COVER		ウツル-ハ°カ°イ° フタ B	1
16. MO-2314-BD6-307						
13		R4305-H0D-E00	THPOAT PLATE		ハリイタ	1
14		118-82404	MAIN FEED DOG		シユオクリハ°	1
15		118-86504	DIFFERENTIAL FEED DOG		フクオクリハ°	1
16		118-93302	UPPER LOOPER GUIDE SUPPORT		ウツル-ハ° カ°イ°サ°エ B	1
17		SS-7151310-TP	SCREW		ウツル-ハ°カ°イ°サ°エ°シ°	2
18		B2515-704-00B	UPPER LOOPER GUIDE COVER		ウツル-ハ°カ°イ° フタ B	1

*All parts other than the above are same as those used in model MO-2314-BD4-300.

上記以外の部品は、MO-2314-BD4-300と同じです。

17. MO-2315-DD4-300



19. MO-2316-DD4-100

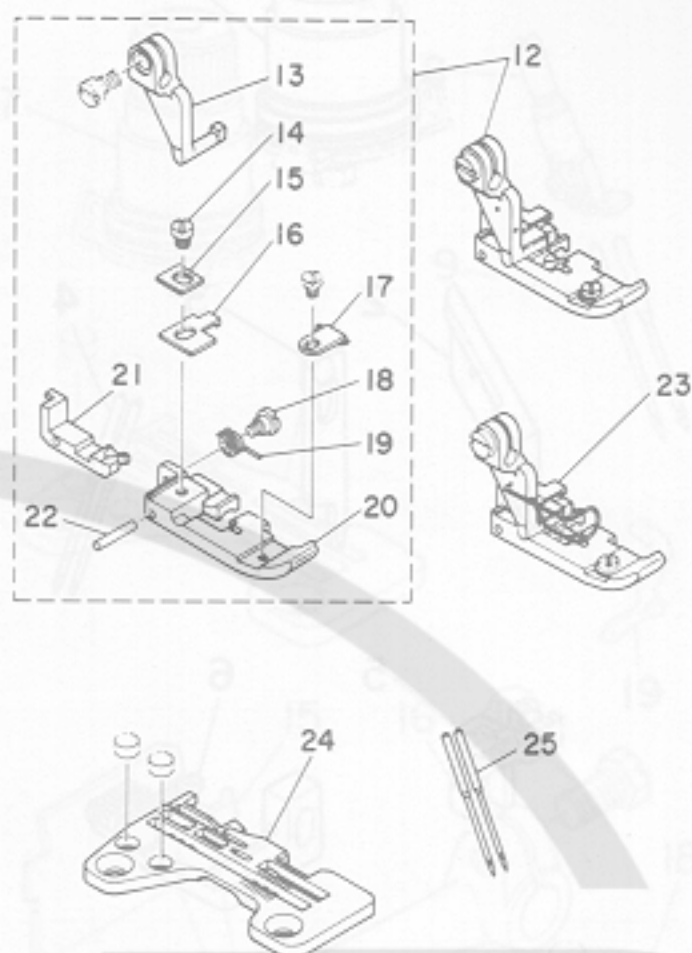

18. MO-2316-BD4-300

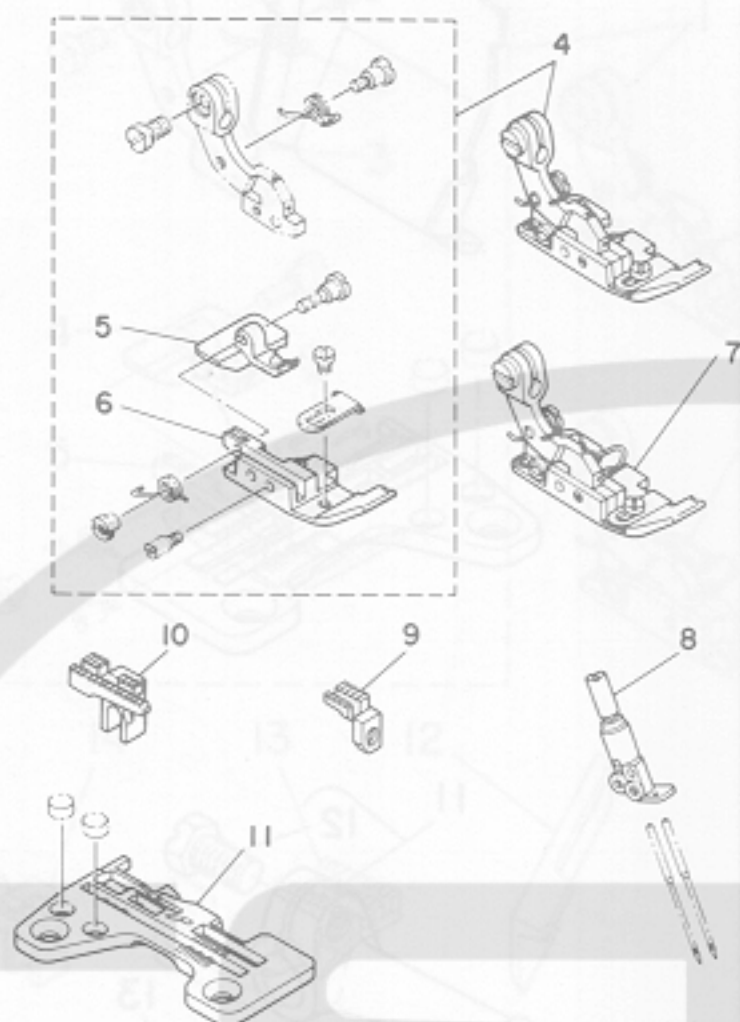

17. MO-2315-DD4-300

Ref. No.	Note 注記	Part No. 品番	Description	E. C. 変更年月	品名	Amt. Req. 数量
1		SS-6090630-SP	SCREW 9/64-40 L=6		ヒラネジ [®] 9/64-40 L=6	1
2		118-88609	UPPER SPREADER		ウツカキ [®] ル=H [®]	1
3		SS-7110710-SL	SCREW 11/64-40 L=7.0		マルヒラネジ [®] 11/64-40 L=7	1
18. MO-2316-BD4-300						
4		118-77354	PRESSER FOOT ASM.		オウエ クミ	1
5		118-75101	REAR PRESSER FOOT		ウシロオウエ	(1)
6		B1507-816-B0C	HINGED TYPE PRESSER FOOT (C)		オウエ C	(1)
7	001	118-77362	PRESSER FOOT ASM.		シ [®] ユウオウエクミ (2ヒ [®] カ [®] -ト [®] ツキ)	1
8		118-70151	NEEDLE CLAMP ASM.		ニシ [®] ユウカン ハリト [®] メ クミ	1
9		118-87304	AUXILIARY FEED DOG		ホシ [®] ヨオクリハ [®]	1
10		118-82602	MAIN FEED DOG		シユオクリハ [®]	1
11		R4505-H0D-000	THROAT PLATE		ハリイタ	1
19. MO-2316-DD4-100						
12		118-79756	PRESSER FOOT ASM.		オウエ クミ	1
13		118-72603	PRESSER FOOT HINGE		オウエヒンジ [®]	(1)
14		SS-6080340-SP	SCREW 1/8-44 L=3.0		ヒラネジ [®] 1/8-44 L=2.9	(1)
15		B1549-816-F00	CHAIN-OF THREAD PRESSER PLATE		カラカンオウエ チヨウセツイ [®]	(1)
16		B1545-816-F00	SPRING		オウエトリツケハ [®] ネ	(1)
17		B1530-816-D0B	AUXILIARY STOPPER		ホシ [®] ヨ トメイタ	(1)
18		SD-0400261-TP	HINGE SCREW		カラカンオウエ ハ [®] ネト [®] メク [®] ンネジ [®]	(1)
19		B1546-816-F00	SPRING		カラカンオウエハ [®] ネ	(1)
20		B1507-816-D0Z	PRESSER FOOT		オウエ	(1)
21		B1508-816-D0Z	CHAIN-OF THREAD PRESSER		カラカンオウエ	(1)
22		B1559-816-000	PIN		ヒンジ [®] ピン	(1)
23	001	118-79764	PRESSER FOOT ASM.		オウエクミ (2ヒ [®] カ [®] -ト [®] ツキ)	1
24		R4508-H0D-800	THROAT PLATE		ハリイタ	1
25		MDC-27080900	NEEDLE DCX27 #9		ハリ DCX27 #9	1

Note (注記) 001 Standard part

*All parts other than the above are same as those used in model MO-2316-DD4-300.

国内は特別注文部品

上記以外の部品は、MO-2316-DD4-300と同じです。

20. MO-2316-DD6-500



21. MO-2316-DF4-300

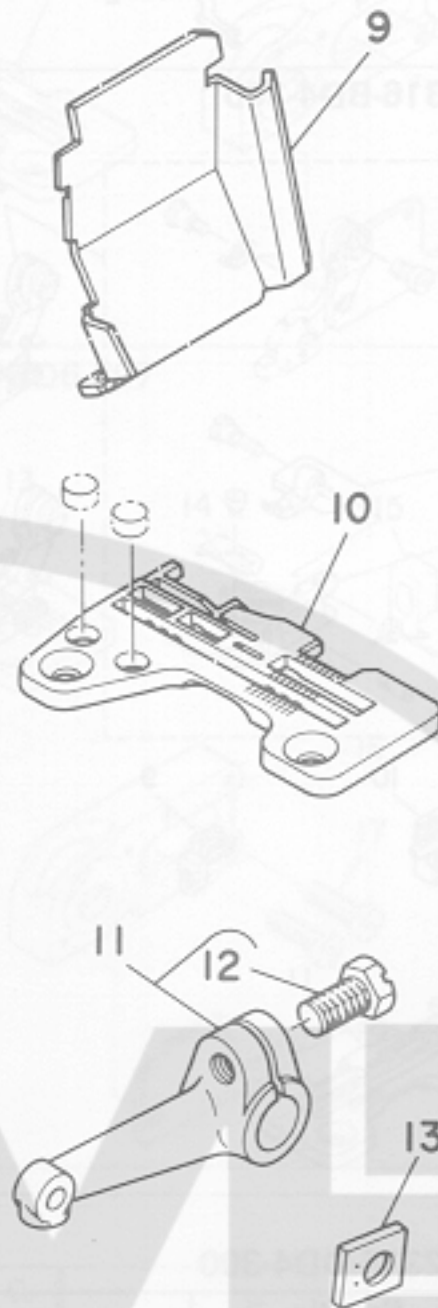

20. MO-2316-DD6-500

Ref. No.	Note 注記	Part No. 品番	Description	E.C. 変更年月	品名	Amt. Req. 数量
1		B3101-704-0B0	TENSION CONTROLLER ASM., RED		イトチヨ-シハ ^ネ アカ クミ	1
2	#01	118-45807	UPPER KNIFE		ウラメス	1
3	#02	118-47407	KNIFE		ヒラメス	1
4		MDC-27081600	NEEDLE DCX27 #16		ハリ DCX27 #16	2
5	*	118-82909	MAIN FEED DOG	D.05/85	119-80802	-
	*	119-80802	MAIN FEED DOG	A.05/85	シユオクリハ ^ム	1
6	*	118-85308	DIFFERENTIAL FEED DOG	D.05/85	119-80901	-
	*	119-80901	DIFFERENTIAL FEED DOG	A.05/85	ツクオクリハ ^ム	1
7		R4508-H0D-F00	THROAT PLATE		ハリイタ	1
8		118-98104	UPPER LOOPER		ウラメ-ハ ^ム	1
21. MO-2316-DF4-300						
9		118-67405	CHIP GUARD COVER		ヌノクス ^カ ハ ^ム -	1
10		R4508-H0F-D00	THROAT PLATE		ハリイタ	1
11		118-31559	LOOPER HOLDER ASM. 9		ウラメ-ハ ^ム ウチ ^ム クミ	1
12		SS-9151210-TP	SCREW 15/64-28 L=11.3		ムツクホ ^ム ルト 15/64-28	(1)
13		118-93609	GAUGE		ウラメ-ハ ^ム カ ^ム イト ^ム ウラ ^ム エ ク ^ム -シ ^ム	1

Note (注記) 001 For export
 002 For domestic use
 *All parts other than the above are same as those used in model MO-2316-DD4-300.

輸出用
 国内用
 上記以外の部品は、MO-2316-DD4-300
 と同じです。

22. MO-2316-FF6-500

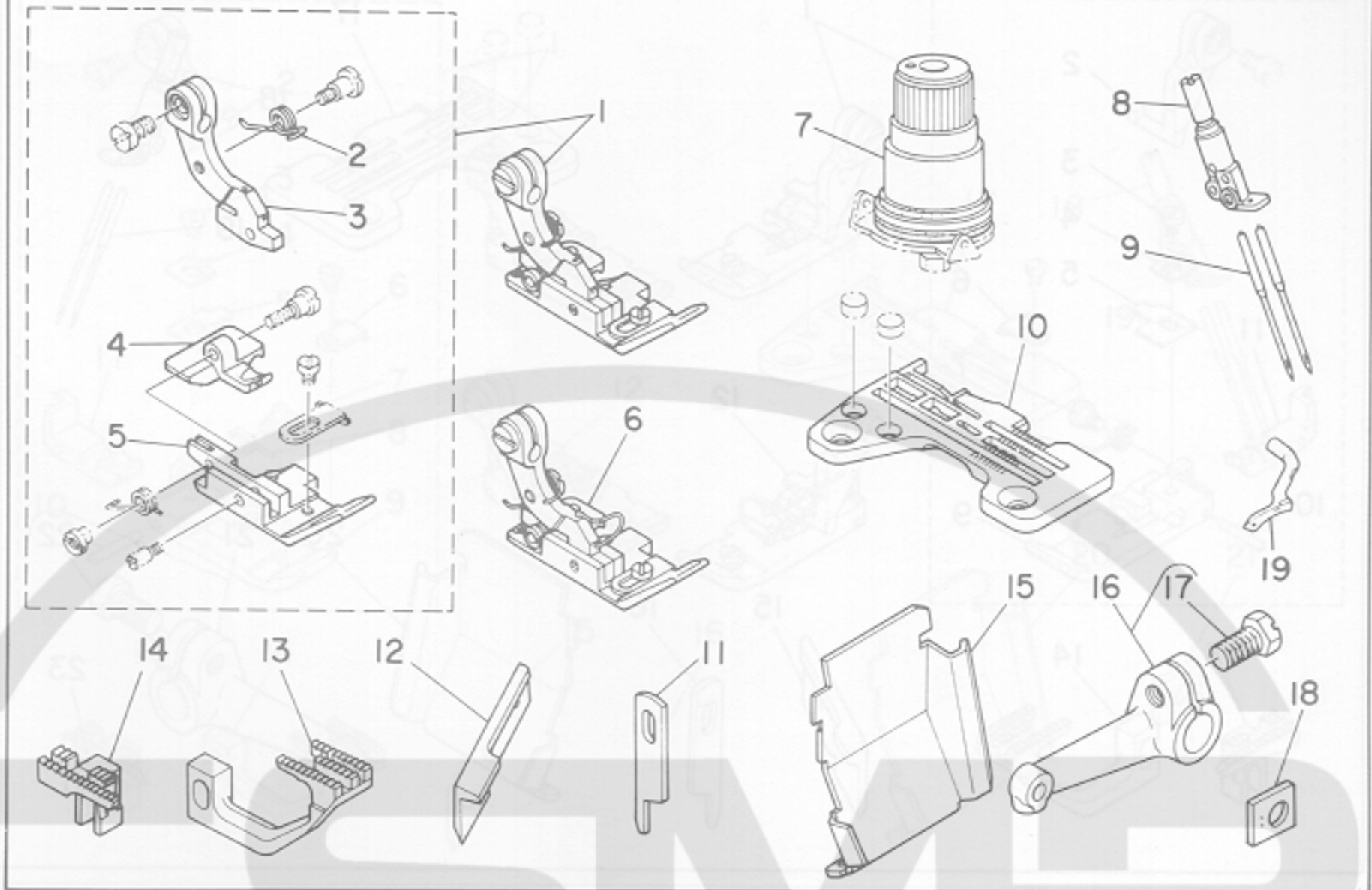

22. MO-2316-FF6-500

Ref. No.	Note 注記	Part No. 品番	Description	E. C. 変更年月	品名	Amt. Req. 数量
1		118-77750	PRESSER FOOT ASM.		オサイ クミ	1
2		B1515-816-00B	PRESSER FOOT ARM SPRING B		オサイウチ° ハ°ネ B	(1)
3		118-72207	PRESSER FOOT HINGE		シ° ヲウオサイ センシ°	(1)
4		118-75507	REAR PRESSER FOOT		クシロオサイ	(1)
5		B1507-816-F0D	HINGED TYPE PRESSER FOOT (D)		オサイ D	(1)
6	001	118-77768	PRESSER FOOT ASM.		シ° ヲウオサイクミ (シヒ°カ°-ト°ツキ)	1
7		B3101-704-0B0	TENSION CONTROLLER ASM., RED		イトチヨ°シハ°ネ アカ クミ	1
8		118-70458	NEEDLE CLAMP ASM.		ニシ° ヲウカン ハリト°メ クミ	1
9		MDC-270B1600	NEEDLE DCx27 #16		ハリ DCx27 #16	2
10		R4612-H0F-G00	THROAT PLATE		ハリイタ	1
11	002	118-47407	KNIFE		ヒラメス	1
12	003	118-45807	UPPER KNIFE		ウラメス	1
13		118-85407	DIFFERENTIAL FEED DOG		フクオクリハ°	1
14		118-83006	MAIN FEED DOG		シユオクリハ°	1
15		118-67405	CHIP GUARD COVER		ヌノクス°カハ°-	1
16		118-31559	LOOPER HOLDER ASM. B		ウクル°ハ°ウチ° クミ	1
17		SS-9151210-TP	SCREW 15/64-28 L=11.8		ロツカクホ°ルト 15/64-28	(1)
18		118-93609	GAUGE		ウクル°ハ° カ°イト°ササニ°ケ°-シ°	1
19		118-88104	UPPER LOOPER		ウクル°ハ°	1

Note (注記) 001 Standard part
 002 For domestic use
 003 For export

*All parts other than the above are same as those used in model MO-2316-DD4-300.

国内は特別注文部品
 国内用
 輸出用

上記以外の部品は、MO-2316-DD4-300と同じです。

23. MO-2316-FF6-100

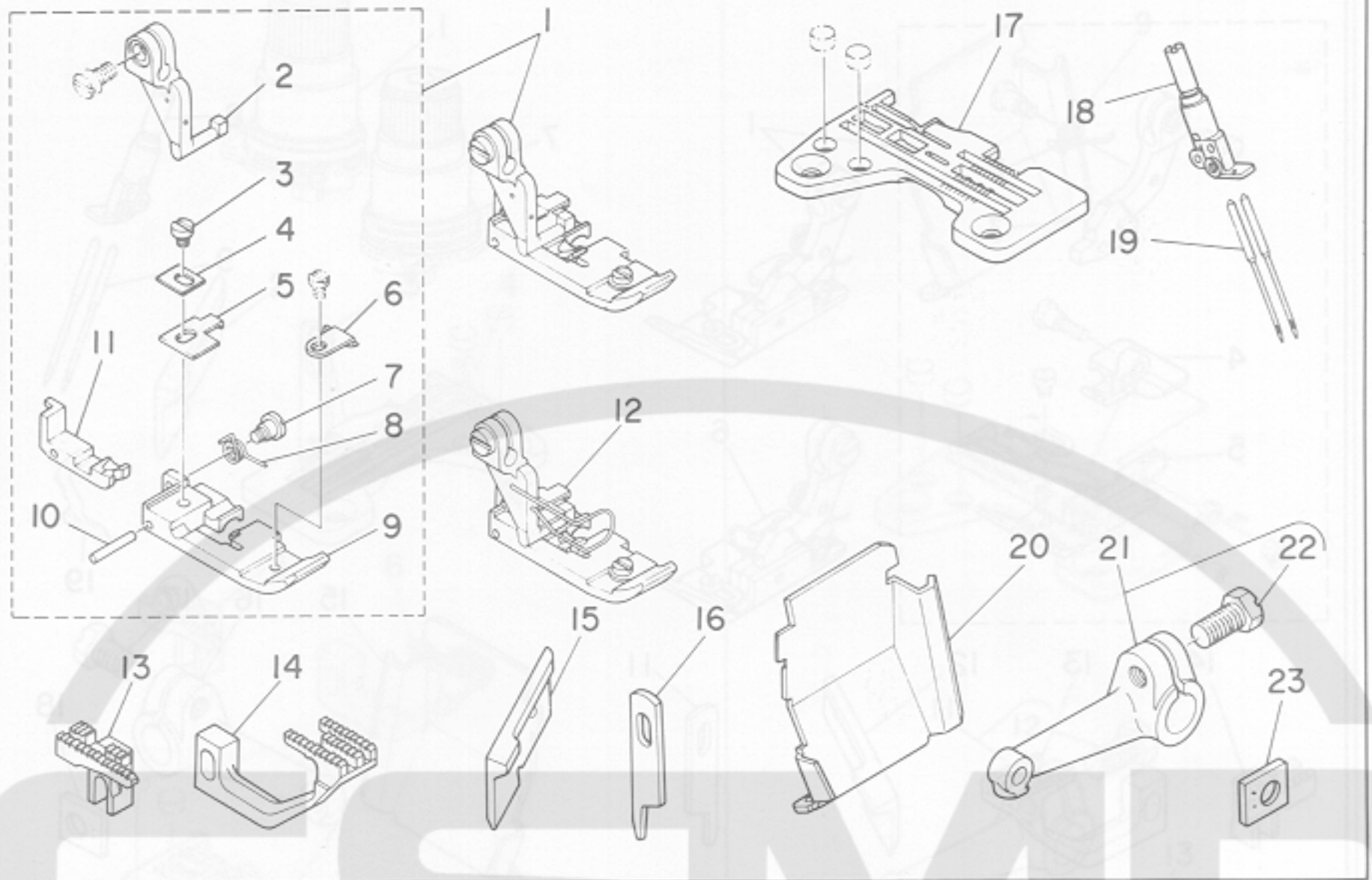

23. MO-2316-FF6-100

Ref. No.	Note 注記	Part No. 品番	Description	E. C. 変更年月	品名	Amt. Req. 数量
1		118-80556	PRESSER FOOT ASM.		オアイ クミ	1
2		118-72603	PRESSER FOOT HINGE		オアイヒンジ	(1)
3		SS-6080340-SP	SCREW 1/8-44 L=3.0		ヒラネシ [※] 1/8-44 L=2.9	(1)
4		B1549-816-F00	CHAIN-OF THREAD PRESSER PLATE		カラカンオアイ チョウセツイ?	(1)
5		B1545-816-F00	SPRING		オアイトリツケハネ	(1)
6		B1530-816-D08	AUXILIARY STOPPER		ホシ [※] ヨ トメイ?	(1)
7		SD-0400261-TP	HINGE SCREW		カラカンオアイ ハネトメメ [※] クネシ [※]	(1)
8		B1546-816-F00	SPRING		カラカンオアイハネ	(1)
9		B1507-816-FC2	PRESSER FOOT		オアイ	(1)
10		B1559-816-000	PIN		ピンシ [※] ヒ [※] ン	(1)
11		B1508-816-FC2	CHAIN-OF THREAD PRESSER		カラカンオアイ	(1)
12	001	118-80564	PRESSER FOOT ASM.		オアイクミ (2ヒ [※] カ [※] ート [※] ツキ)	1
13		118-84004	MAIN FEED DOG		シユオクリハ [※]	1
14		118-86009	DIFFERENTIAL FEED DOG		フクオクリハ [※]	1
15	002	118-45807	UPPER KNIFE		クワメス	1
16	003	118-47407	KNIFE		ヒラメス	1
17		R4612-H0F-B00	THROAT PLATE		ハリイ?	1
18		118-70458	NEEDLE CLAMP ASM.		ニシ [※] ユクカン ハリトメ クミ	1
19		MDC-270B0900	NEEDLE DCX27 #9		ハリ DCX27 #9	2
20		118-67405	CHIP GUARD COVER		ヌノクス [※] カハ [※] ー	1
21		118-31559	LOOPER HOLDER ASM, B		クワ [※] ル [※] -ハ [※] ク [※] チ [※] クミ	1
22		SS-9151210-TP	SCREW 15/64-28 L=11.8		ロツカクホ [※] ルト 15/64-28	(1)
23		118-93609	GAUGE		クワ [※] ル [※] -ハ [※] カイト [※] ササ [※] イ [※] ケ [※] ー [※] シ [※]	1

Note (注記) 001 Standard part
 002 For export
 003 For domestic use
 *All parts other than the above are same as those used in model MO-2316-DD4-300.

国内は特別注文部品
 輸出用
 国内用
 上記以外の部品は、MO-2316-DD4-300
 と同じです。

24. MO-2316-RH6-100

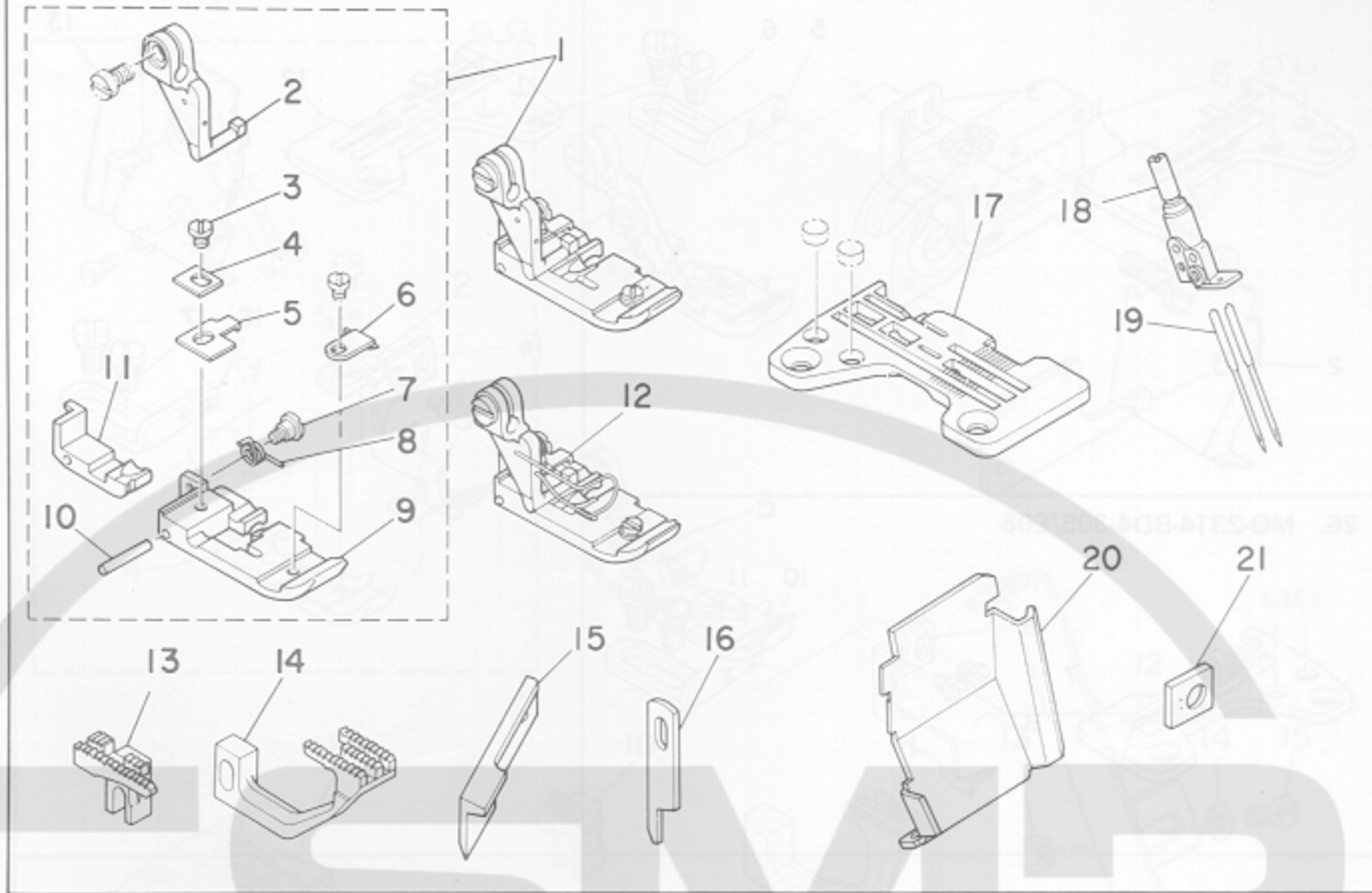

24. MO-2316-RH6-100

Ref. No.	Note 注記	Part No. 品番	Description	E. C. 変更年月	品名	Amt. Req. 数量
1		118-80952	PRESSER FOOT ASM.		オワイ クミ	1
2		118-72603	PRESSER FOOT HINGE		オワイヒンジ	(1)
3		SS-6080340-SP	SCREW 1/8-44 L=3.0		ヒラネシ 1/8-44 L=2.9	(1)
4		B1549-816-F00	CHAIN-OF THREAD PRESSER PLATE		カラカンオワイ チョウソウイ	(1)
5		B1545-816-F00	SPRING		オワイトリツケバネ	(1)
6		B1530-816-D08	AUXILIARY STOPPER		オシヨトメタ	(1)
7		SD-0400261-TP	HINGE SCREW		カラカンオワイ ハネストメネジ	(1)
8		B1546-816-F00	SPRING		カラカンオワイバネ	(1)
9		118-73205	PRESSER FOOT		オワイ	(1)
10		B1559-816-0C0	PIN		ヒンシヒン	(1)
11		118-75606	REAR PRESSER FOOT		カラカンオワイ	(1)
12	001	118-80960	PRESSER FOOT ASM.		オワイクミ (ユビカートツキ)	1
13		118-84004	MAIN FEED DOG		シユオクリハ	1
14		118-86009	DIFFERENTIAL FEED DOG		フクオクリハ	1
15	002	118-45807	UPPER KNIFE		ウメス	1
16	003	118-47407	KNIFE		ヒラメス	1
17		R4617-H0H-800	THROAT PLATE		ハリイタ	1
18		118-70557	NEEDLE CLAMP ASM.		ニシユウカン ハリトメクミ	1
19		MDC-27080900	NEEDLE DCX27 #9		ハリ DCX27 #9	2
20		118-67504	CHIP GUARD COVER		スノクスカハ	1
21		118-93609	GAUGE		ウフルハ カイトサライ ケーシ	1

Note (注記) 001 Standard part
 002 For export
 003 For domestic use

*All parts other than the above are same as those used in model MO-2316-DD4-300.

国内は特別注文部品
 輸出用
 国内用

上記以外の部品は、MO-2316-DD4-300
 と同じです。

25. MO-2304-0D4-305/E05

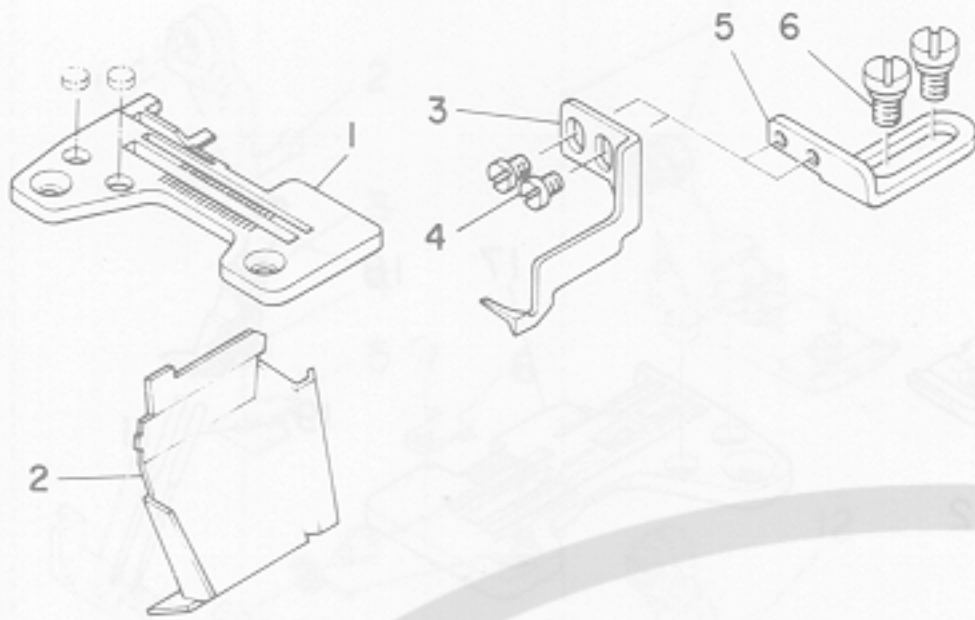

27. MO-2316-DD4-305/E07

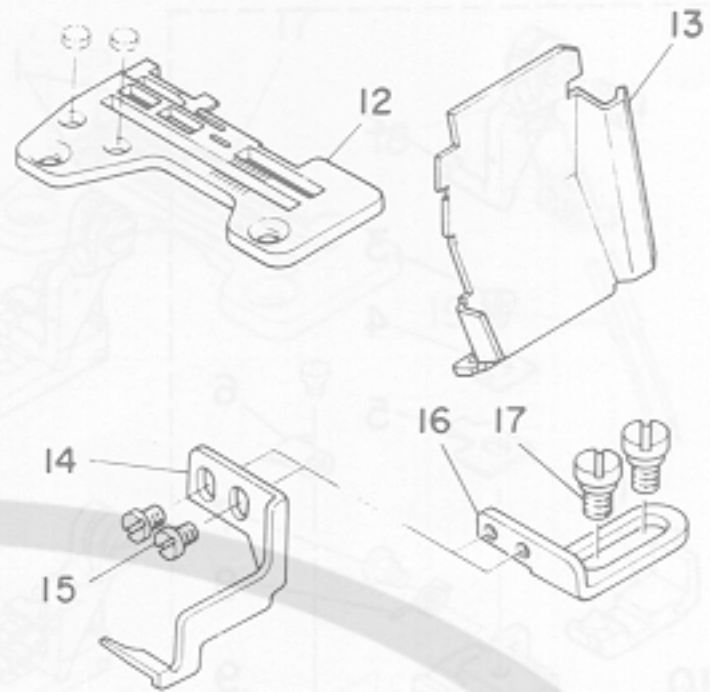

26. MO-2314-BD4-305/E08

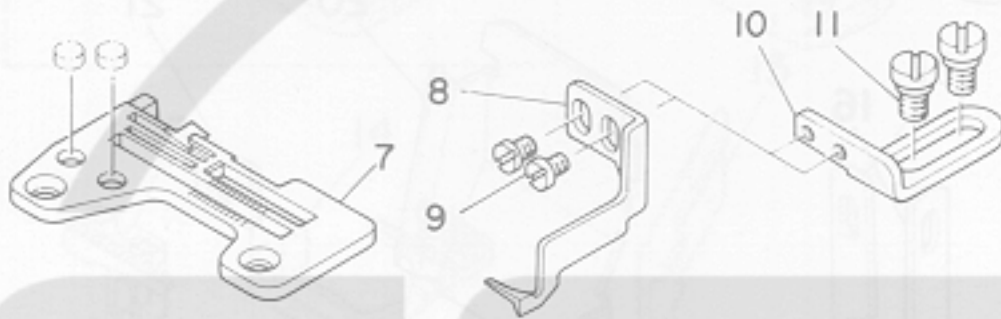

25. MO-2304-0D4-305/E05

Ref. No.	Note	Part No. 品番	Description	E. C. 変更年月	品名	Amt. Req. 数量
1		R4200-H00-D0B	THROAT PLATE		ハリタ	1
2		118-67207	CHIP GUARD COVER		スノクス*カバー	1
3		118-92205	REGULATOR HOOK		チョウセツツメ	1
4		SS-5090420-SP	SCREW 9/64-40 L=3.5		トラスネジ* 9/64-40 L=3.5	2
5		118-92403	REGULATOR HOOK SET BASE		チョウセツツメ トリツケタイ	1
6		SD-0640211-SP	HINGE SCREW D= 6.35 H= 2.1		タ*ンスシ* D=6.35 H=2.1	2

*All parts other than the above are same as those used in model MO-2304-0D4-300.

上記以外の部品は、MO-2304-0D4-300と同じです。

26. MO-2314-BD4-305/E08

7		R4205-H00-E0A	TROAT PLATE (E08)		ハリタ (E-08)	1
8		118-92205	REGULATOR HOOK		チョウセツツメ	1
9		SS-5090420-SP	SCREW 9/64-40 L=3.5		トラスネジ* 9/64-40 L=3.5	2
10		118-92403	REGULATOR HOOK SET BASE		チョウセツツメ トリツケタイ	1
11		SD-0640211-SP	HINGE SCREW D= 6.35 H= 2.1		タ*ンスシ* D=6.35 H=2.1	2

*All parts other than the above are same as those used in model MO-2314-BD4-300.

上記以外の部品は、MO-2314-BD4-300と同じです。

27. MO-2316-DD4-305/E07

12		R4508-H00-D0C	THROAT PLATE		ハリタ	1
13		118-67405	CHIP GUARD COVER		スノクス*カバー	1
14		118-92304	REGULATOR HOOK		チョウセツツメ	1
15		SS-5090420-SP	SCREW 9/64-40 L=3.5		トラスネジ* 9/64-40 L=3.5	2
16		118-92403	REGULATOR HOOK SET BASE		チョウセツツメ トリツケタイ	1
17		SD-0640211-SP	HINGE SCREW D= 6.35 H= 2.1		タ*ンスシ* D=6.35 H=2.1	2

*All parts other than the above are same as those used in model MO-2316-DD4-300.

上記以外の部品は、MO-2316-DD4-300と同じです。

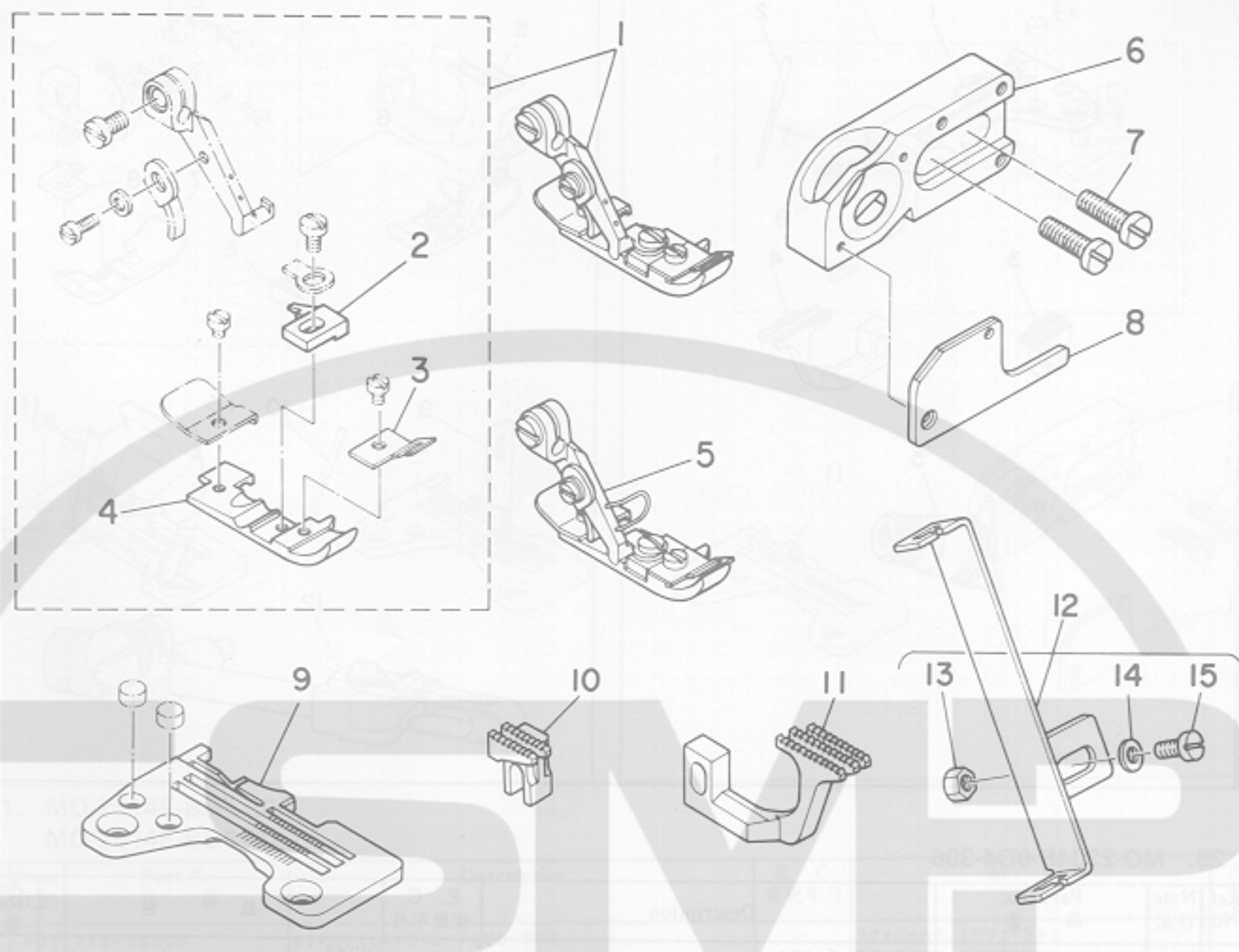
28. MO-2314-BD6-340
MO-2314-BD6-347

28. MO-2314-BD6-340, MO-2314-BD6-347

Ref. No.	Note 注記	Part No. 品番	Description	E. C. 変更年月	品名	Amt. Req. 数量
1		118-79251	PRESSER FOOT ASM.		オワイ クミ	1
2		B1509-814-B0B	STITCH TONGUE		イトスハ・リタイ	(1)
3		B1531-814-000	TAPE GUIDE PLATE		テープ・アツナイタ	(1)
4		B1507-814-B0B	PRESSER FOOT		テープ・イレ オワイ	(1)
5	001	118-79269	PRESSER FOOT ASM.		オワイクミ (2ピカ・オートツキ) G02	1
6	002	118-93302	UPPER LOOPER GUIDE SUPPORT		ウツル・ハカイト・ササエ B	1
7	002	SS-7151310-TP	SCREW		ウツル・ハカイト・ササエシ	2
8	002	B2515-704-00B	UPPER LOOPER GUIDE COVER		ウツル・ハカイト・フタ B	1
9		R4305-H0D-E00	THROAT PLATE		ハリイタ	1
10		118-82404	MAIN FEED DOG		シユオクリハ	1
11		118-86504	DIFFERENTIAL FEED DOG		フクオクリハ	1
12		MAQ-056010A0	TAPE GUIDE ASM.		テープ・アツナイ クミ	1
13		NS-6090310-SP	NUT 9/64-40		ロツカクナツト 9/64-40	(1)
14		WP-0371016-SD	WASHER 3.7X8X1		ヒラサ・カネ 3.7X8X1	(1)
15		SS-7090910-SP	SCREW 9/64-40 L= 8.5		マルヒラサシ 9/64-40 L=8.5	(1)

Note (注記) 001 For BD6-340
002 For BD6-347

*All parts other than the above are same as those used in model MO-2314-BD4-300.

上記以外の部品は、MO-2314-BD4-300と同じです。

29. MO-2304B-OD4-306

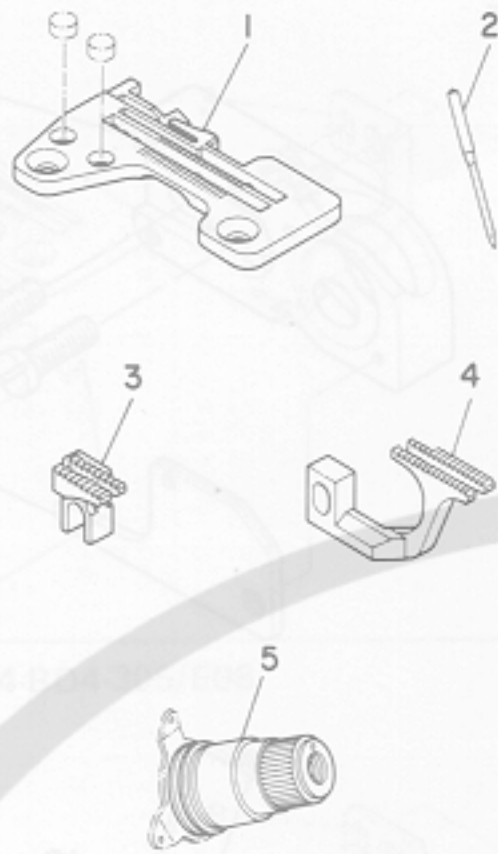

30. MO-2304E-OD4-20B/F

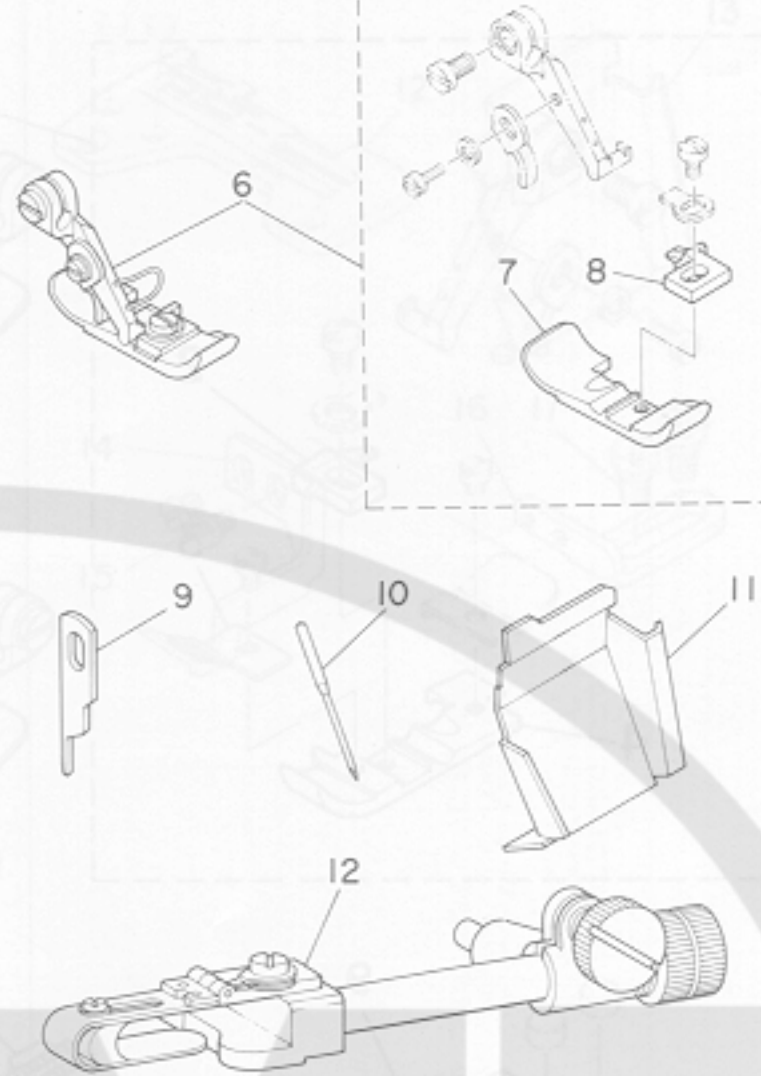

29. MO-2304B-OD4-306

Ref. No.	Note 注記	Part No. 品番	Description	E. C. 変更年月	品名	Amt. Req. 数量
1		R4200-H0D-DOE	THROAT PLATE		ハリイタ	1
2		MC-0336007-50	NEEDLE B-27 NM75		ハリ B-27 75	1
3		115-97101	MAIN FEED DOG		シユオクリハ*	1
4		118-86207	DIFFERENTIAL FEED DOG		フクオクリハ*	1
5		115-50159	TENSION CONTROLLER ASM., ORANGE		イトチヨウシハ* ネ クミ (ムラサキ)	1

30. MO-2304E-OD4-20B/F

6		118-78568	PRESSER FOOT ASM.		オワエクミ (1ヒカ-トツキ)	1
7		B1507-805-000-A	PRESSER FOOT		オワエ	(1)
8		118-74807	STITCH TONGUE		イトスハリタ* イ	(1)
9		118-47506	KNIFE		ヒラメス	1
10		MDC-27080900	NEEDLE DCX27 #9		ハリ DCX27 #9	1
11		118-89003	CHIP GUARD COVER		ヌノクス* カハ-	1
12		MAT-80101LAB	BLIND HEMMING ATTACHMENT ASM. (B)		ヌソビ* アツツメント クミ	1

*All parts other than the above are same as those used in model MO-2304-OD4-300.

上記以外の部品は、MO-2304-OD4-300と同じです。

31. MO-2314E-BD4-306
MO-2314E-BD6-306

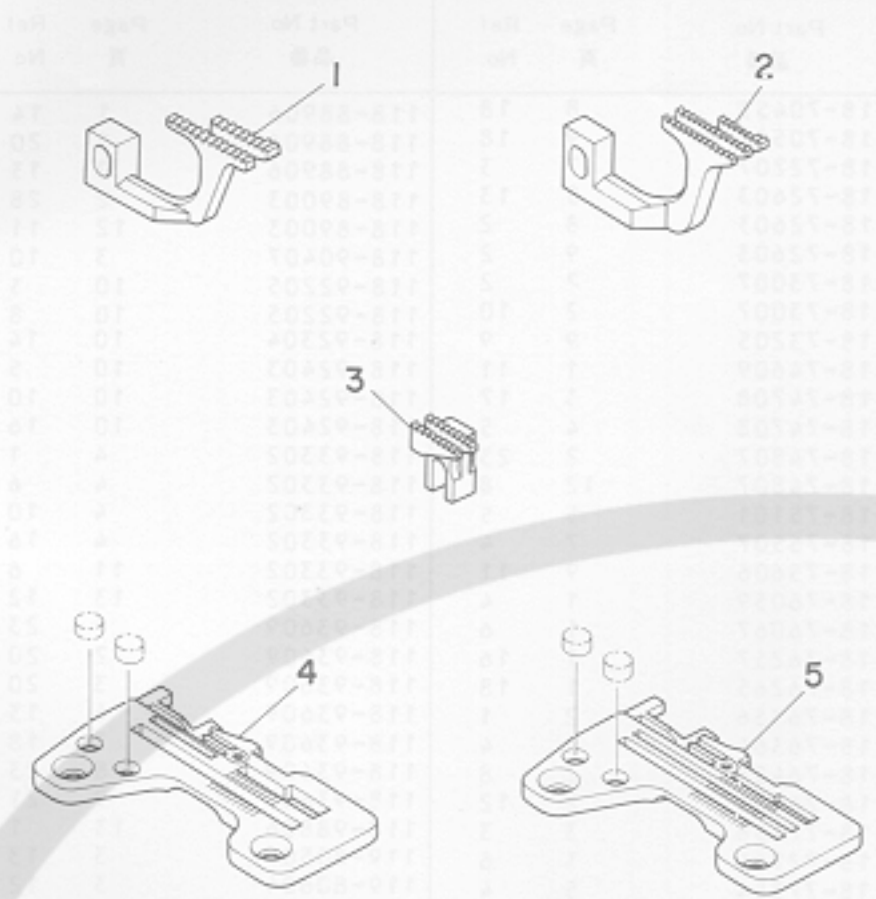

32. MO-2314-BD4-307/D025

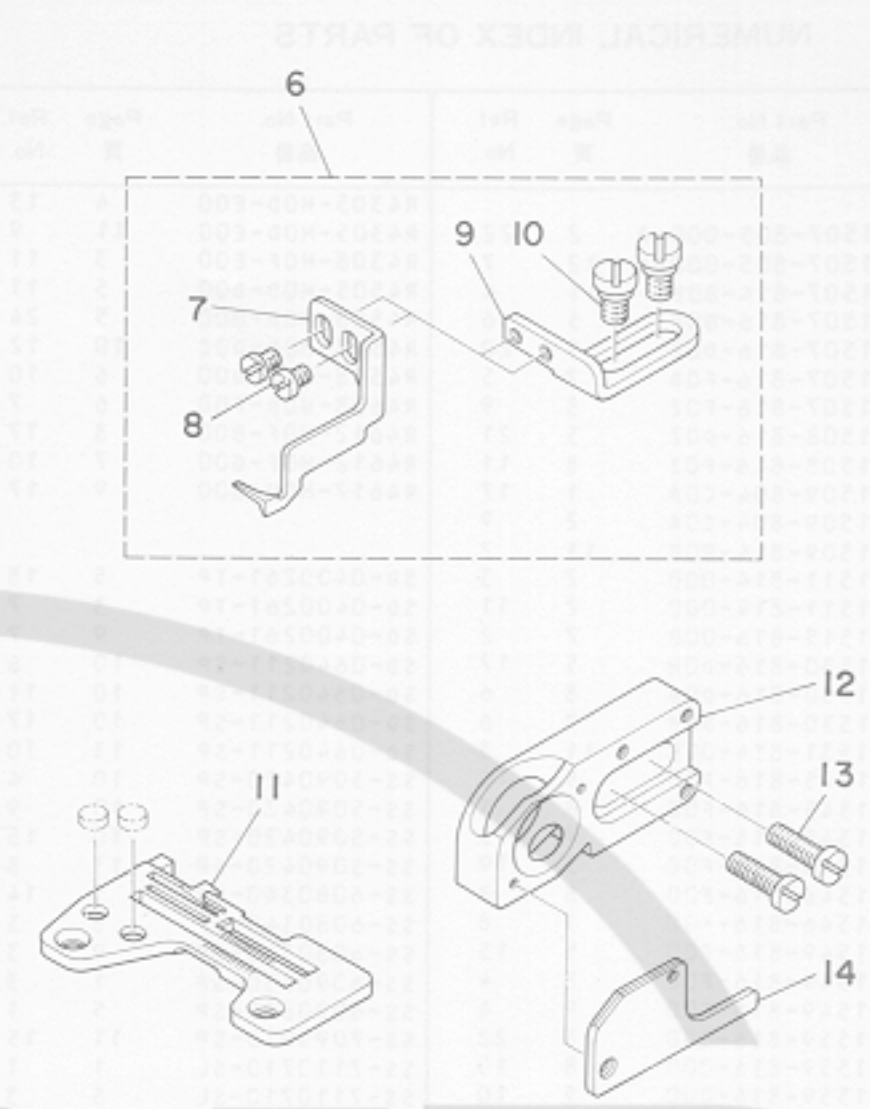

31. MO-2314E-BD4-306
MO-2314E-BD6-306

Ref. No.	Note 注記	Part No. 品番	Description	E. C. 変更年月	品名	Amt. Req. 数量
1	#01	118-98806	DIFFERENTIAL FEED DOG		フクオクリハ (リツフ*ツキ)	1
2	#02	118-36900	DIFFERENTIAL FEED DOG		フクオクリハ (リツフ*ツキ)	1
3	#02	118-82404	MAIN FEED DOG		シユオクリハ	1
4	#01	R4205-H0D-E0B	THROAT PLATE		ハリタ (リツフ*ツキ)	1
5	#02	R4305-H0D-E0C	THROAT PLATE		ハリタ (リツフ*ツキ)	1

32. MO-2314-BD4-307/D025

6		MAD-025010A0	REGULATOR HOOK ASM.		チヨクセツツメ クミ	1
7		MAD-02501000	REGULATOR HOOK		チヨクセツツメ	(1)
8		SS-5090420-SP	SCREW 9/64-40 L=3.5		トラスネジ 9/64-40 L=3.5	(2)
9		MAD-02502000	REGULATOR HOOK SET BASE		チヨクセツツメ トリツケベース	(1)
10		SD-0640211-SP	HINGE SCREW D=6.35 H=2.1		クワンネジ D=6.35 H=2.1	(2)
11		R4205-H0D-E0A	TROAT PLATE (E08)		ハリタ (E-08)	1
12		118-93302	UPPER LOOPER GUIDE SUPPORT		ウツル-ハ カイト*リサエ B	1
13		SS-7151310-TP	SCREW		ウツル-ハ カイト*リサエネジ	2
14		B2515-704-009	UPPER LOOPER GUIDE COVER		ウツル-ハ カイト* 79 B	1

NUMERICAL INDEX OF PARTS

索引

Part No. 品番	Page 頁	Ref. No.	Part No. 品番	Page 頁	Ref. No.	Part No. 品番	Page 頁	Ref. No.	Part No. 品番	Page 頁	Ref. No.
B1507-805-000-A	2	22	R4305-H0D-E00	4	13	118-70458	8	18	118-88906	1	14
B1507-805-000-A	12	7	R4305-H0D-E00	11	9	118-70557	9	18	118-88906	1	20
B1507-814-80B	11	4	R4308-H0F-E00	3	11	118-72207	7	3	118-88906	2	13
B1507-816-80C	5	6	R4505-H0D-D00	5	11	118-72603	5	13	118-89003	2	28
B1507-816-D0Z	5	20	R4508-H0D-800	5	24	118-72603	3	2	118-89003	12	11
B1507-816-F0D	7	5	R4508-H0D-D0C	10	12	118-72603	9	2	118-90407	3	10
B1507-816-F0Z	3	9	R4508-H0F-D00	6	10	118-73007	2	2	118-92205	10	3
B1508-816-D0Z	5	21	R4608-H0D-F00	6	7	118-73007	2	10	118-92205	10	8
B1508-816-F0Z	3	11	R4612-H0F-800	3	17	118-73205	9	9	118-92304	10	14
B1509-804-C0A	1	17	R4612-H0F-G00	7	10	118-74609	1	11	118-92403	10	5
B1509-804-C0A	2	9	R4617-H0H-800	9	17	118-74708	3	17	118-92403	10	10
B1509-814-80B	11	2				118-74708	4	5	118-92403	10	16
B1511-814-000	2	3	SD-0400261-TP	5	18	118-74807	2	23	118-93302	4	1
B1511-814-000	2	11	SD-0400261-TP	3	7	118-74807	12	8	118-93302	4	6
B1515-816-00B	7	2	SD-0400261-TP	9	7	118-75101	5	5	118-93302	4	10
B1530-816-D0B	5	17	SD-0640211-SP	10	6	118-75507	7	4	118-93302	4	16
B1530-816-D0B	3	6	SD-0640211-SP	10	11	118-75606	9	11	118-93302	11	6
B1530-816-D0B	9	6	SD-0640211-SP	10	17	118-76059	1	4	118-93302	13	12
B1531-814-000	11	3	SD-0640211-SP	10	17	118-76067	1	6	118-93609	1	23
B1545-816-F00	5	16	SD-0640211-SP	13	10	118-76257	1	16	118-93609	2	20
B1545-816-F00	8	5	SS-5090420-SP	10	4	118-76265	1	18	118-93609	3	20
B1545-816-F00	9	5	SS-5090420-SP	10	9	118-76356	2	1	118-93609	6	13
B1546-816-F00	5	19	SS-5090420-SP	10	15	118-76364	2	4	118-93609	7	18
B1546-816-F00	8	3	SS-5090420-SP	13	8	118-76455	2	8	118-93609	8	23
B1546-816-F00	9	8	SS-6080340-SP	5	14	118-76463	2	12	118-93609	9	21
B1549-816-F00	5	15	SS-6080340-SP	3	3	118-77156	3	3	118-98806	13	1
B1549-816-F00	3	4	SS-6080340-SP	9	3	118-77164	3	6	119-80505	3	13
B1549-816-F00	9	4	SS-6090630-SP	1	3	118-77354	5	4	119-80604	3	12
B1559-816-000	5	22	SS-6090630-SP	5	1	118-77362	5	7	119-80802	6	5
B1559-816-000	8	10	SS-7090910-SP	11	15	118-77750	7	1	119-80901	6	6
B1559-816-000	9	10	SS-7110710-SL	1	1	118-77768	7	6			
B2515-704-00B	4	3	SS-7110710-SL	5	3	118-78550	2	21			
B2515-704-00B	4	8	SS-7151310-TP	4	2	118-78568	2	24			
B2515-704-00B	4	12	SS-7151310-TP	4	7	118-78568	12	6			
B2515-704-00B	4	18	SS-7151310-TP	4	11	118-79251	11	1			
B2515-704-00B	11	8	SS-7151310-TP	4	17	118-79269	11	5			
B2515-704-00B	13	14	SS-7151310-TP	11	7	118-79756	5	12			
B3101-704-0B0	6	1	SS-7151310-TP	13	13	118-79764	5	23			
B3101-704-0B0	7	7	SS-9151210-TP	1	22	118-80556	8	1			
			SS-9151210-TP	2	19	118-80564	3	12			
			SS-9151210-TP	6	12	118-80952	9	1			
			SS-9151210-TP	7	17	118-80960	9	12			
			SS-9151210-TP	8	22	118-81455	1	10			
MAD-025010A0	13	6				118-81471	1	12			
MAD-02501000	13	7				118-81554	3	16			
MAD-02502000	13	9				118-81554	4	4			
MAQ-056010A0	11	12	WP-0371015-SD	11	14	118-81570	3	18			
MAT-80101LAB	2	27				118-82206	2	5			
MAT-80101LAB	12	12				118-82206	2	15			
MC-0336007-50	12	2	115-50159	12	5	118-82404	3	22			
MDC-100B0800	1	9	115-97101	12	3	118-82404	4	14			
MDC-270B0900	1	15	117-90508	3	4	118-82404	11	10			
MDC-270B0900	3	15	117-90607	3	5	118-82404	13	3			
MDC-270B0900	5	25	117-90706	3	12	118-82503	3	13			
MDC-270B0900	3	19	117-92900	1	5	118-82602	5	10			
MDC-270B0900	9	19	118-31559	1	21	118-82909	6	5			
MDC-270B0900	12	10	118-31559	2	18	118-83006	7	14			
MDC-270B1400	2	17	118-31559	6	11	118-83303	2	15			
MDC-270B1400	3	9	118-31559	7	16	118-84004	3	13			
MDC-270B1600	6	4	118-31559	3	21	118-84004	9	13			
MDC-270B1600	7	9	118-45807	6	2	118-85100	2	6			
			118-45807	7	12	118-85100	2	16			
			118-45807	3	15	118-85308	6	6			
NS-6090310-SP	11	13	118-45807	9	15	118-85407	7	13			
			118-45906	2	26	118-85605	2	16			
			118-47407	6	3	118-86009	3	14			
			118-47407	7	11	118-86009	9	14			
			118-47407	8	16	118-86207	12	4			
			118-47407	9	16	118-86504	3	23			
R4200-H0A-C00	1	7	118-47506	2	25	118-86504	4	15			
R4200-H0D-D0B	10	1	118-47506	12	9	118-86504	11	11			
R4200-H0D-D0E	12	1	118-67207	10	2	118-86504	13	2			
R4200-H0E-D00	1	13	118-67405	6	9	118-86900	1	8			
R4200-H0F-D00	1	19	118-67405	7	15	118-87007	1	8			
R4205-H0D-E0A	10	7	118-67405	3	20	118-87205	3	14			
R4205-H0D-E0A	13	11	118-67405	10	13	118-87304	5	9			
R4205-H0D-E0B	13	4	118-67504	9	20	118-88005	3	7			
R4205-H0E-E0C	3	19	118-69757	3	2	118-88104	6	8			
R4205-H0E-E0D	4	9	118-69955	3	8	118-88104	7	19			
R4206-H0D-E00	3	1	118-70151	5	8	118-88609	1	2			
R4300-H0D-E00	2	7	118-70458	7	8	118-88609	5	2			
R4300-H0F-E00	2	14									
R4305-H0D-E0C	13	5									
R4305-H0D-E00	3	21									